

ZX HOIST



Street



Certificate No.FM13635
Quality Management ISO 9001



MADE IN ENGLAND

Street

“PERFORMANCE THROUGH EVOLUTION AND INNOVATION”

Street



“To achieve the highest possible levels of performance and reliability it is necessary to continuously learn from experience, invest in R&D and pay attention to even the smallest possibility for improvement. Only then can new bench marks for efficient performance and operating reliability be set.

Only then can a technology be said to be truly proven.”



ZX HOIST : the next generation.

The new ZX hoist generation evolved from the most rigorous application of this philosophy. The original ZX hoist which was launched 10 years ago established Street as a world leader in hoisting technology and has been the company's best ever selling product with an unparalleled record for reliability and endurance in a vast range of applications and environments worldwide. When it came to developing the next generation it was therefore completely logical to retain the best aspects,

The new ZX Hoist formula for safe and efficient lifting

The new ZX hoist sets the benchmarks in the crane industry. It provides a series of unique benefits for the user. ZX epitomises intelligent design-for easy load handling-impressive performance - exceptional safety levels.

We invite you to compare the following hoist specification with any in the world and we think you will agree ZX represents unbeatable value for money and great investment.



such as the highly successful parallel configuration of the motor and drum. Every function of the hoist was reviewed and a whole series of innovations applied to provide new levels of user-friendliness and performance.

Finally we optimised every component using the latest finite element design techniques and a passionate commitment to every performance detail. The result is an easy to operate high endurance hoist in a state-of-the-art technology. A hoist designed to fulfill expectations and improve our customer's productivity. A hoist for tomorrow's world in which only the most productive will prosper.



"A hoist for tomorrow's world in which, only the most productive will prosper."

Street

ZX HOIST : operating and safety features.

IP 55 steel electrical control cubicle.

- Functional design with hinged door makes all components easily accessible.
- All electrical equipment incorporates heavy duty, quick release, plug and socket cable connectors for fast simple assembly.
- Better heat dissipation by the finned aluminium heat sink to transfer heat out of the control cubicle when air venters are used on travel.
- Inverter control for trolley drive
- A phase failure relay prevents uncontrolled movement of the hoist should one or more phases of incomet.
- Hours in service meter records the total time the motor is energised
- Panel wiring is ferruled and fully identified to the connection terminal



Direct drive trolley with flangeless cross travel wheels and side rollers for high durability and reduced wear.

- The monorail trolley design is an outstanding feature of the Street design concept.
- It is proven by experience and generally accepted in the industry that for long term reliability and durability in travel gearing the trolley wheel should be directly driven, avoiding the need for an overhung pinion driving a spur on the trolley wheel.
- Direct drive via hardened and precision ground gears permanently immersed in oil.
- The traverse drive is removable without the need to remove or interfere with gearing or travel wheels. The trolley wheels are also easily removable.
- Sealed for life self-aligning permanently lubricated bearings in the trolley frame ensure long life even under maximum loading.
- Sturdy flangeless steel wheels and guide rollers eliminate the problem of wheel flange wear and increase beam life.



No!



Balance Weight

Trolley reaction roller avoids the need for a counter weight to increase wheel life.

- Spring roller acting on the underside of the beam eliminates the need for a counter weight.
- Increases life of the wheel rolling surface as a result of lighter hoist weight.
- Pre-loading on the mechanism significantly reduces wheel slip on light load or no load start up.
- Reduced shipping and transport cost as a result of lower weight and volume.
- Caters for beam flange thickness up to 35mm.



Patented torque arm safe load cut-out device. (Capacity restrictor)

- Protects the operator and the machine.
- Measures all the load the hoist mechanism is transmitting (not just the load in one or two ropes).
- Can be easily adjusted to the required capacity.
- Does not reduce available height of lift.
- Activated directly by the load, does not rely on measuring electrical current.

Over-hoisting and over-lift limit switches.

- Over-hoisting and over-lift are prevented by individual switches (one for over-hoist and one for over-lift).
- The switches are activated as it travels along the drive positions can be adjusted to



Precision hoist gearbox with hardened and ground gears/drum

- Gears permanently immersed in oil safety and reliability year after year.
- The hollow shaft gearbox directly drives the hoist drum shaft, assisted by an overhung pinion and barrel spur arrangement outside the gear train.
- Gears are case hardened and precision ground with special tip relief for long life and long reliability.
- Gear train can be viewed through a removable hoist gearbox inspection cover.
- ZX6 gearbox now improved MS rating for S and F speeds utilizing H4.
- Gear train can be viewed through the removable inspection cover.

Superior load safety.

- A hoist brake acts on a gearbox shaft not a motor shaft as is the case with competitor hoists.
- When the hoist brake is applied, the load will remain secure even if the hoist motor is removed.
- Automatic braking in the event of a power failure.
- Low maintenance DC disk brake fitted on gearbox shaft ensures load remains secure in event of motor shaft or coupling failure.
- Health and safety compliant asbestos free brake lining.
- Hand-release mechanism fitted as standard.

Bottom Block.

- New ergonomic design for improved safety and handling.
- "Sealed for life" maintenance free bearings fitted to all sheaves.
- Robust cast aluminium sheave covers.
- Spring loaded safety catch fitted as standard.

- 
- Close coupled hoist motor mounting with damping coupling prolongs motor and gearbox life.

Swiveling

Swiveling of the hook
 limit switches
 (for over-lower)
 by the rope guide
 and the cut-out
 at the application.



Heavy duty rope guide ensures positive rope scrolling and prevents damage in 'slack-rope' conditions.

- Robust functional design - the product of 60 years experience.
- Specially selected oil impregnated nylon material, highly resistant to breaking or permanent distortion. The material properties include self-lubrication and a good elastic memory range.
- Spring loaded lever clamping band to prevent rope build up damaging the rope guide if the operator lowers the hook block onto an object and causes slack in the ropes.
- Rope guide reduces wear on the hoist rope and drums.
- Easy to install.

High-strength galvanised wire ropes.

- Compact strand structure with improved tensile strength.
- Enhanced fatigue strength for durability under cyclic bending.
- Galvanised steel rope strands for maximum corrosion protection.

Extra hoist drum security

- Continuous shaft through the hoist drum
- Barrel retention "spigots"
- Self-aligning bearings at each end of the drum to take up deflection



Shafts.

...ing the need for final reduction
 ...
 ... and crowning for smooth running

... on cover.
 ... and HS motors respectively



...vibration
 ...flow life.

continuous primary gear shaft through
 in double bearing to set alignment.

Designed for improved ventilation and easy access to key components.

- External hoist motor to optimise cooling and maximum accessibility
- Remote mounting of the hoist motor and brake prevents heat transfer in either direction
- Flange mounting IEC Standards 60034-7
- Heavy duty two speed hoist motor with built in protection against over-heating.
- Cylindrical rotor fan cooled design.
- Overheating protection in the motor winding is standard.
- Class "F" insulation 155°C
- Ambient temperatures -20°C up to +50°C at an altitude less than 1000m, above sea level
- Humidity 5-95% Non condensing
- IP 55 protection against ingress of dust particles and water.



Street

NEW ZX HOIST MODELS



MODEL : ZX06 SINGLE GIRDER HOISTS
Capacity of 2.5, 3.2 and 5 Tons
Lifting Height 6, 10 and 15 Meter



MODEL : ZX06 DOUBLE GIRDER HOISTS
Capacity of 2.5, 3.2, and 5 Tons
Lifting Height 6, 10 and 15 Meter

SINGLE GIRDER TROLLEY

*** Trolley Reaction Roller Avoids The Need For A Counter Weight To Increase wheel life Street Drive Trolley With Flangeless Cross Travel Wheels And Side Rollers For High Durability And Reduced Wear



MODEL : ZX08 SINGLE GIRDER HOISTS
Capacity of 5, 6.3, 8, 10, 12.5,
16, 20 and 25 Tons
Lifting Height 8, 12 and 15 Meter

Sp...
• L...
• M...
• D...
• A...
• C...
• V...
• T...
• E...
• 2...
• P...
• H...
• H...
• Q...
• S...



**MODEL : ZX08 DOUBLE GIRDER
SINGLE ROPE HOISTS**

Capacity of 16, 20 and 25 Tons
Lifting Height 6, and 10 Meter



**MODEL : ZX10 DOUBLE GEAR BOX
TWIN ROPE HOISTS**

Capacity up to 40 and 50 Tons
Lifting Height up to 15 Meter
True Vertical Lift Hoist Ultra Short
Head Room Design Combination of
Very Heavy Duty Ratings
Fast Hoisting Speeds

Special Features :

- Head Room & Low Profile Bay.
- Mechanism Torque Arm Safe Overload Device.
- Direct Drive Cross Travel Wheel On Trolley.
- Phase Failure Relay Prevent Movement Of The Hoist.
- Inverter Travel Drives Control By Inverter 2 Step Variable Speed.
- Fanned Aluminium Heat-Sink to Transfer Heat Out IP55.
- Inertia Damping Coupling Prolongs Hoist Motor And Gear Box Life.
- Internal Electro Magnetic DC Disc Brake On Gear Box With Hand Release.
- Needs Heavy Duty Poles Change Hoist Motor With Built In The Overheat Protection.
- Precision Engineered And Hardened Gears Permanently Immersed In Oil.
- Heavy Duty Engineering Nylon Rope Guide.
- High Strength Galvanised Wire Ropes.
- Quick Release Heavy Duty Plug & Socket Connection.
- Special Models Are Available For Ambient Temperatures 50 Degree C.



**MODEL : ZX10 SINGLE GEAR BOX
SINGLE ROPE HOISTS**
Capacity of 20, 25 and 32 Tons
Lifting Height 10 and 15 Meter

DOUBLE GIRDER TROLLEY



**MODEL : ZX10 SINGLE GEAR BOX
TWIN ROPE HOISTS**

Capacity up to 16, 20, 25 and 32 Tons
Lifting Height up to 11 Meter True Vertical
Lift Hoist Ultra Short Head Room Design
Combination of Very Heavy Duty Ratings
Fast Hoisting Speeds

single girder



ZX06 Single Girder Hoists

Low headroom construction is a standard design feature of ZX monorail hoists with capacities ranging from 0.5 tonne for ZX06 models and 0-25 tonne for the ZX08.

At each capacity we offer a huge combination of lifting speeds and lifting heights giving the user maximum flexibility.

All popular capacities are available with M5 duty ratings (FEM 2m) and in most capacities duty ratings of M6 (FEM 3m) and M7 (FEM 4m) are also available.

Low headroom models are fully adjustable to accommodate a wide range of beam flanges:

- ZX6 - 150mm - 500mm*
- ZX8 - 200mm - 500mm* (0-12.5t)
- ZX8 - 300mm - 700mm* (12.5-25t)

*Special solutions available for beams outside these ranges



ZX08 Single Girder Hoists

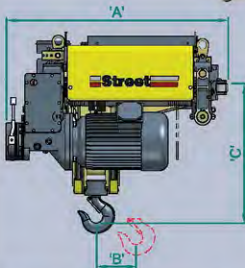

ZX06 HOIST SINGLE GIRDER

Hoist Model	S.W.L.		Duty	Lifting Height m.	Hoist		Rope		Transverse		Dimensions (mm.)				Weight Kg.	Wheel Dia.	
	Tons	BS			FEM	2 Speeds (m/min)	Motor (Kw.)	Dia (mm.)	Reeving	Inverter (m/min)	Motor (Kw.)	A	B	C			
												*300	*400	*500			
ZX062-3FoNM5H052	2.5	M5	2m	13	10.3/3.4	7.8/2.6	8	2:1	0-2-20	0.25	978	213	631	752	871	329	100
ZX062-3FoLM5H052	2.5	M5	2m	20	10.3/3.4	7.8/2.6	8	2:1	0-2-20	0.25	1208	328	631	752	871	329	100
ZX062-3FoEM5H052	2.5	M5	2m	30	10.3/3.4	7.8/2.6	8	2:1	0-2-20	0.25	1553	492	631	752	871	410	100
ZX064-3FoNM7H031	2.5	M7	4m	6.5	5/1.8	3.7/1.2	8	4:1	0-2-20	0.25	978	106	585	706	825	350	100
ZX064-3FoLM7H031	2.5	M7	4m	10	5/1.8	3.7/1.2	8	4:1	0-2-20	0.25	1208	163	585	706	825	386	100
ZX064-3FoEM7H031	2.5	M7	4m	15	5/1.8	3.7/1.2	8	4:1	0-2-20	0.25	1553	245	585	706	825	439	100
ZX064-3FoNM7K041	3.2	M7	4m	6.5	5.3/1.8	4.7/1.6	8	4:1	0-2-20	0.25	978	106	585	706	825	350	100
ZX064-3FoLM7K041	3.2	M7	4m	10	5.3/1.8	4.7/1.6	8	4:1	0-2-20	0.25	1208	163	585	706	825	386	100
ZX064-3FoEM7K041	3.2	M7	4m	15	5.3/1.8	4.7/1.6	8	4:1	0-2-20	0.25	1553	245	585	706	825	439	100
ZX064-3FoNM5K052	5	M5	2m	6.5	5.2/1.8	7.8/2.6	8	4:1	0-2-20	0.25	978	106	585	706	825	350	100
ZX064-3FoLM5K052	5	M5	2m	10	5.2/1.8	7.8/2.6	8	4:1	0-2-20	0.25	1208	163	585	706	825	386	100
ZX064-3FoEM5K052	5	M5	2m	15	5.2/1.8	7.8/2.6	8	4:1	0-2-20	0.25	1553	245	585	706	825	439	100

** Remark : Excerpt from our product portfolio. Above are standard model, Special specification is available for buyer, Please contact Distributor.

der

monorail hoists

capacity up to 25 tons

One of the many technical advantages which ensures the high efficiency and reliability of this range of single girder hoists is the use of direct gear travelling machinery with no open gears or wheel flanges.



**ZX08 Standard
Low Headroom Hoists**

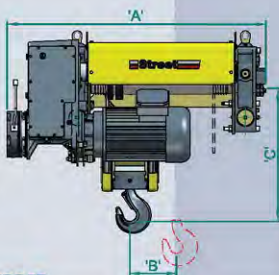

All low headroom models have improved headroom dimensions giving a lower roof height requirement.

The compact design of the hoists provides optimal top hook position, ideal for modern low profile buildings.

Side and end hook approaches have been designed to maximise factory floor coverage for a more productive work space.

ZX08 HOIST SINGLE GIRDER

Hoist Model	S.W.L.		Duty	Lifting Height m.	Hoist		Rope		Transverse		Dimensions (mm.)			Weight Kg.	Wheel Dia.		
	Tons	BS			FEM	2 Speeds (m/min)	Motor (Kw)	Dia (mm.)	Reeving	Inverter (m/min)	Motor (Kw.)	A	B			C	
												*300	*400	*500			
ZX082-4SoNM6K074	5	M6	3m	16	8.7/2.2	11.2/2.8	13	2:1	0-2-20	0.37	1437	300	600	646	785	853	160
ZX082-4SoLM6K074	5	M6	3m	24	8.7/2.2	11.2/2.8	13	2:1	0-2-20	0.37	1697	430	600	646	765	930	160
ZX082-4SoEM6K074	5	M6	3m	40	8.7/2.2	11.2/2.8	13	2:1	0-2-20	0.37	2267	716	600	646	765	1098	160
ZX084-4FoNM7L074	6.3	M7	4m	8	5.4/1.3	11.2/2.8	13	4:1	0-2-20	0.37	1437	145	566	612	731	928	160
ZX084-4FoLM7L074	6.3	M7	4m	12	5.4/1.3	11.2/2.8	13	4:1	0-2-20	0.37	1697	215	566	612	731	1011	160
ZX084-4FoEM7L074	6.3	M7	4m	20	5.4/1.3	11.2/2.8	13	4:1	0-2-20	0.37	2267	358	566	612	731	1190	160
ZX084-4FoNM6N074	8	M6	3m	8	5.3/1.3	11.2/2.8	13	4:1	0-2-20	0.37	1437	145	566	612	731	928	160
ZX084-4FoLM6N074	8	M6	3m	12	5.3/1.3	11.2/2.8	13	4:1	0-2-20	0.37	1697	215	566	612	731	1011	160
ZX084-4FoEM6N074	8	M6	3m	20	5.3/1.3	11.2/2.8	13	4:1	0-2-20	0.37	2267	358	566	612	731	1190	160
ZX084-4FoNMS0088	10	M5	2m	8	5.5/1.4	13.0/3.2	13	4:1	0-2-20	0.37	1437	145	566	612	731	928	160
ZX084-4FoLMS0088	10	M5	2m	12	5.5/1.4	13.0/3.2	13	4:1	0-2-20	0.37	1697	215	566	612	731	1011	160
ZX084-4FoEMS0088	10	M5	2m	20	5.5/1.4	13.0/3.2	13	4:1	0-2-20	0.37	2267	358	566	612	731	1190	160
ZX084-4FoNM4P108	12.5	M4	1Am	8	5.6/1.4	19.2/4.8	13	4:1	0-2-20	0.37	1437	145	566	612	731	928	160
ZX084-4FoLM4P108	12.5	M4	1Am	12	5.6/1.4	19.2/4.8	13	4:1	0-2-20	0.37	1697	215	566	612	731	1011	160
ZX084-4FoEM4P108	12.5	M4	1Am	20	5.6/1.4	19.2/4.8	13	4:1	0-2-20	0.37	2267	358	566	612	731	1190	160
ZX086-4FoNMSR088	16	M5	2m	5.5	3.7/1	13.0/3.2	13	8:1	0-2-20	2x0.37	2205	100	1175	1175	1175	1867	160
ZX086-4FoLMSR088	16	M5	2m	8	3.7/1	13.0/3.2	13	8:1	0-2-20	2x0.37	2465	143	1175	1175	1175	2104	160
ZX086-4FoEMSR088	16	M5	2m	13	3.7/1	13.0/3.2	13	8:1	0-2-20	2x0.37	3035	240	1175	1175	1175	2328	160
ZX086-4FoNMR108	16	M4	1Am	5.5	3.7/1	19.2/4.8	13	8:1	0-2-20	2x0.37	2205	100	1175	1175	1175	1867	160
ZX086-4FoLMR108	16	M4	1Am	8	5.9/1.4	19.2/4.8	13	8:1	0-2-20	2x0.37	2465	143	1175	1175	1175	2104	160
ZX086-4FoEMR108	16	M4	1Am	13	5.9/1.4	19.2/4.8	13	8:1	0-2-20	2x0.37	3035	240	1175	1175	1175	2328	160
ZX088-4EoLM4S108	20	M4	1Am	6	4.4/1.1	19.2/4.8	13	8:1	0-2-20	2x0.37	2465	108	1282	1282	1282	2244	160
ZX088-4EoEM4S108	20	M4	1Am	10	4.4/1.1	19.2/4.8	13	8:1	0-2-20	2x0.37	3305	180	1282	1282	1282	2453	160
ZX088-4XoLM4T108	25	M4	1Am	6	3.3/0.9	19.2/4.8	13	8:1	0-2-20	2x0.37	2465	108	1282	1282	1282	2244	160
ZX088-4XoEM4T108	25	M4	1Am	10	3.3/0.9	19.2/4.8	13	8:1	0-2-20	2x0.37	3305	180	1282	1282	1282	2453	160

** Remark : Excerpt from our product portfolio. Above are standard model, Special specification is available for buyer, Please contact Distributor.

ZX10 dou

single rope hoists capacity up to 32 tons

Zero lateral hook movement over the full lifting height results in equal trolley wheel loads. This, in-turn, allows the crane designer to optimise the crane dimensions and weight of the crane structure generally resulting in savings in the building structure or supporting steelwork.



**ZX10 Double Girder Trolley
32 Tons**

These hoists sit at the top of the ZX range for the highest lifting capacities or for very heavy duty ratings.

Faster lifting speeds and greater lifting heights at lesser capacities are also available.

Key features include double scroled hoist drum and genuine true vertical lift for enhanced safety and precision handling.

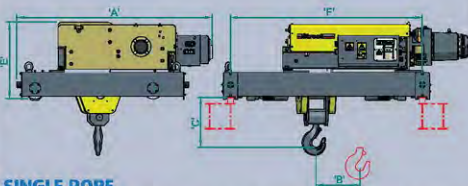
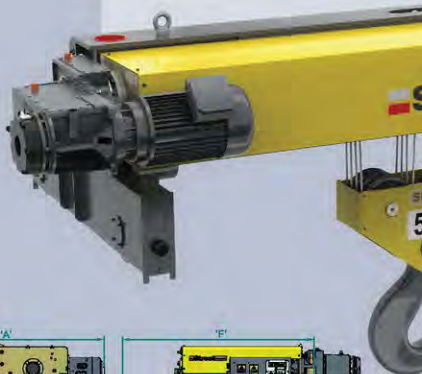

ZX10 SS HOIST SINGLE GIRDER AND SINGLE ROPE

Hoist Model	S.W.L.		Duty	Lifting Height m.	Hoist			Rope		Transverse		Dimensions (mm.)					Weight Kg.	Wheel Dia.
	Tons	BS			FEM	2 Speeds (m/min)	Motor (Kw.)	Dia (mm.)	Reeving	Inverter (m/min)	Motor (Kw.)	A	B	C	E	F		
ZX1004-4EaSB8CM5J107-SS	20	M5	2m	10	4.1/1	19.2/4.8	18	4:1	0-2-20	2x0.37	2043	216	517	787	2000	1876	200	
ZX1004-4EaNB8CM5J107-SS	20	M5	2m	15	4.1/1	19.2/4.8	18	4:1	0-2-20	2x0.37	2043	318	517	787	2600	2113	200	
ZX1004-4EaLB8CM5J107-SS	20	M5	2m	21	4.1/1	19.2/4.8	18	4:1	0-2-20	2x0.37	2043	416	517	787	3200	2351	200	
ZX1004-4EaEB8CM5J107-SS	20	M5	2m	23	4.1/1	19.2/4.8	18	4:1	0-2-20	2x0.37	2043	466	517	787	3200	2435	200	
ZX1004-4EaVB8CM5J107-SS	20	M5	2m	29	4.1/1	19.2/4.8	18	4:1	0-2-20	2x0.37	2043	591	517	787	4000	2738	200	
ZX1006-4CaSB8CM5K107-SS	25	M5	2m	7	3.3/0.8	19.2/4.8	18	6:1	0-2-20	2x0.37	2043	144	613	792	2000	1904	200	
ZX1006-4CaNB8CM5K107-SS	25	M5	2m	10	3.3/0.8	19.2/4.8	18	6:1	0-2-20	2x0.37	2043	210	613	792	2600	2143	200	
ZX1006-4CaLB8CM5K107-SS	25	M5	2m	14	3.3/0.8	19.2/4.8	18	6:1	0-2-20	2x0.37	2043	277	613	792	3200	2383	200	
ZX1006-4CaEB8CM5K107-SS	25	M5	2m	15	3.3/0.8	19.2/4.8	18	6:1	0-2-20	2x0.37	2043	310	613	792	3200	2469	200	
ZX1006-4CaVB8CM5K107-SS	25	M5	2m	19	3.3/0.8	19.2/4.8	18	6:1	0-2-20	2x0.37	2043	394	613	792	4000	2771	200	
ZX1006-4EaSB8CM5M107-SS	32	M5	2m	7	2.8/0.7	19.2/4.8	18	6:1	0-2-20	2x0.37	2043	144	613	792	2000	1904	200	
ZX1006-4EaNB8CM5M107-SS	32	M5	2m	10	2.8/0.7	19.2/4.8	18	6:1	0-2-20	2x0.37	2043	210	613	792	2600	2143	200	
ZX1006-4EaLB8CM5M107-SS	32	M5	2m	14	2.8/0.7	19.2/4.8	18	6:1	0-2-20	2x0.37	2043	277	613	792	3200	2383	200	
ZX1006-4EaEB8CM5M107-SS	32	M5	2m	15	2.8/0.7	19.2/4.8	18	6:1	0-2-20	2x0.37	2043	310	613	792	3200	2469	200	
ZX1006-4EaVB8CM5M107-SS	32	M5	2m	19	2.8/0.7	19.2/4.8	18	6:1	0-2-20	2x0.37	2043	394	613	792	4000	2771	200	

** Remark : Excerpt from our product portfolio. Above are standard model, Special specification is available for buyer, Please contact Distributor.

ble girder

This range of hoists is available in a robust heavy duty open winch format with drum flanges instead of rope guides.

As an optional safety enhancement, true vertical lift models of ZX hoists are available with separate ropes in the left and right hand scrolls with a compensating bar rather than a sheave.

twin rope hoists

capacity up to 50 tons



ZX10 Double Girder Trolley
50 Tons



ZX10 Double Girder Trolley
40 Tons

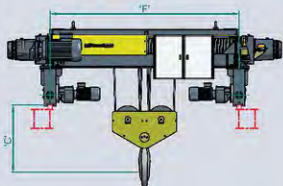
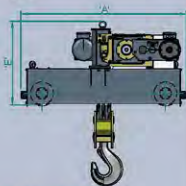

ZX10 ST HOIST SINGLE GEARBOX AND TWIN ROPE

Hoist Model	S.W.L.		Duty	Lifting Height m.	Hoist		Rope		Transverse		Dimensions (mm.)					Weight Kg.	Wheel Dia.
	Tons	BS			FEM	2 Speeds (m/min)	Motor (Kw.)	Dia (mm.)	Reeving	Inverter (m/min)	Motor (Kw.)	A	B	C	E		
ZX1008-4CoN3AM5108-ST	16	M5	2m	11	3.7/0.9	19.2/4.8	13	8:2	0-2-20	2X0.37	2086	-	906	886	2000	2016	200
ZX1008-4CoL3AM5108-ST	16	M5	2m	15	3.7/0.9	19.2/4.8	13	8:2	0-2-20	2X0.37	2086	-	920	886	2000	2277	200
ZX1008-4CoV3AM5108-ST	16	M5	2m	22	3.7/0.9	19.2/4.8	13	8:2	0-2-20	2X0.37	2086	-	946.5	886	3600	2682	200
ZX1008-4CoN3AM5J108-ST	20	M5	2m	11	3.7/0.9	19.2/4.8	13	8:2	0-2-20	2X0.37	2086	-	906	886	2000	2016	200
ZX1008-4CoL3AM5J108-ST	20	M5	2m	15	3.7/0.9	19.2/4.8	13	8:2	0-2-20	2X0.37	2086	-	920	886	2000	2277	200
ZX1008-4CoV3AM5J108-ST	20	M5	2m	22	3.7/0.9	19.2/4.8	13	8:2	0-2-20	2X0.37	2086	-	946.5	886	3600	2682	200
ZX1008-4EaN3AM5K107-ST	25	M5	2m	11	3.1/0.8	19.2/4.8	13	8:2	0-2-20	2X0.37	2088	-	906	886	2000	2016	200
ZX1008-4EoL3AM5K107-ST	25	M5	2m	15	3.1/0.8	19.2/4.8	13	8:2	0-2-20	2X0.37	2088	-	920	886	2000	2277	200
ZX1008-4EoV3AM5K107-ST	25	M5	2m	22	3.1/0.8	19.2/4.8	13	8:2	0-2-20	2X0.37	2088	-	946.5	886	3600	2682	200
ZX1012-4CaN3AM5M107-ST	32	M5	2m	7	2.5/0.7	19.2/4.8	13	12:2	0-2-20	2X0.37	2086	-	810	990	2000	2175	250
ZX1012-4CaL3AM5M107-ST	32	M5	2m	10	2.5/0.7	19.2/4.8	13	12:2	0-2-20	2X0.37	2086	-	810	990	2600	2448	250
ZX1012-4CaV3AM5M107-ST	32	M5	2m	14	2.5/0.7	19.2/4.8	13	12:2	0-2-20	2X0.37	2086	-	810	990	3600	2950	250

ZX10 DT HOIST SINGLE GEARBOX AND TWIN ROPE

Hoist Model	S.W.L.		Duty	Lifting Height m.	Hoist		Rope		Transverse		Dimensions (mm.)					Weight Kg.	Wheel Dia.
	Tons	BS			FEM	2 Speeds (m/min)	Motor (Kw.)	Dia (mm.)	Reeving	Inverter (m/min)	Motor (Kw.)	A	B	C	E		
ZX1012-4CaNeDM5O107-DT	40	M5	2m	7	3.3/0.8	2x19.2/4.8	16	12:2	0-2-20	2X0.55	2280	-	965.5	1117	2000	2484	315
ZX1012-4CaLeDM5O107-DT	40	M5	2m	10	3.3/0.8	2x19.2/4.8	16	12:2	0-2-20	2X0.55	2280	-	965.5	1149	2600	4162	315
ZX1012-4CaVeDM5O107-DT	40	M5	2m	15	3.3/0.8	2x19.2/4.8	16	12:2	0-2-20	2X0.55	2280	-	965.5	1149	3600	4347	315
ZX1012-4CaNeDM4Q107-DT	50	M4	1Am	7	3.3/0.8	2x19.2/4.8	16	12:2	0-2-20	2X0.55	2280	-	965.5	1117	2000	3484	315
ZX1012-4CaLeDM4Q107-DT	50	M4	1Am	10	3.3/0.8	2x19.2/4.8	16	12:2	0-2-20	2X0.55	2280	-	965.5	1149	2600	4162	315
ZX1012-4CaVeDM4Q107-DT	50	M4	1Am	15	3.3/0.8	2x19.2/4.8	16	12:2	0-2-20	2X0.55	2280	-	965.5	1149	3600	4347	315

** Remark : Excerpt from our product portfolio. Above are standard model, Special specification is available for buyer, Please contact Distributor.

Classification of Mechanisms

FEM 9.511	10 _m	1C _m	1B _m	1A _m	2 _m	3 _m	4 _m	5 _m
BS 2573 P2	M1	M2	M3	M4	M5	M6	M7	M8
Hoist	Intermittent ratio (R1%)		25	30	40	50	60	>60
	No. of starts per hour (S/h)		150	180	240	300	360	>360
	No. of cycles per hours (C/h)		25	30	40	50	60	>60
Trolley	Intermittent ratio (R1%)		20	25	30	40	50	60
	No. of starts per hour (S/h)		120	150	180	240	300	360
	No. of cycles per hours (C/h)		20	25	30	40	50	60
Two-Speed Double polarity motor								
No. of starts per hour (S/h)	Main speed		1/3 (33.3% of total starts per hour)					
	Slow speed		2/3 (66.7% of total starts per hour)					
Operating time per day	Main speed		2/3 (66.7% of average operating time per day)					
	Slow speed		1/3 (33.3% of average operating time per day)					
Used in temporary duty	Operating time at main speed (min.)		15	15	30	30	60	>60
	Operating time at slow speed (min.)		2,5	3	3,5	4	5	6
	Maximum number of starts per hour (s/h)		10	10	10	10	10	10

For applying to the hoist mechanisms are classified into the groups depending on operating conditions The group into which a mechanism is classified is determined by the following factor :

- Class of operating time
- Load spectrum

Class of operating time

The class of operating time indicates the average period per day during which a mechanism is in operation (see table 1). A mechanism is considered to be in operation when it is in motion.

For mechanisms not regularly used during the year the average operating time per day is determined by the ratio of the annual operating time to 250 working days per year.

The higher classes of operating time apply only in such cases where a mechanism is operated during more than one shift per day.

Table 1

Average operating time per day (hours)

$$\text{Operating time/day (h)} = \frac{2 \times \text{lifting height (m)} \times \text{number of cycles per hour} \times \text{working time/day (h)}}{60 \text{ (minutes per hour)} \times \text{lifting speed (m/min)}}$$

Lifting height = The average hook travel under actual operating conditions (meter)

Cycles per hour = The average number of complete ascent/descent operations in an hour

Working time/day = The time during which the hoist is used on a working day (hour)

Lifting speed = The average lifting speed (normally the maximum lifting speed) at which the load cycles are performed. (Meter per minute)

Class of operating time	Average operating time per day	Calculated total operating time
FEM	BS	(hours)
V0.06	T0	≤ 0.12
V0.12	T1	≤ 0.25
V0.25	T2	≤ 0.5
V0.5	T3	≤ 1
V1	T4	≤ 2
V2	T5	≤ 4
V3	T6	≤ 8
V4	T7	≤ 16
V5	T8	≤ 16
		(hours)
		200
		400
		800
		1600
		3200
		6300
		12500
		25000
		50000

Load spectrum

The load spectrum indicates to what extent a mechanism or part thereof is subject to maximum stress or whether it is subject to smaller load only.

For an exact classification into groups the cubic mean value k referred to the safe working load is required. It is calculated by using the following formula :

$$k = \sqrt[3]{(\beta_1 + \gamma)^3 \cdot t_1 + (\beta_2 + \gamma)^3 \cdot t_2 + \dots + \gamma^3 \cdot t_\Delta}$$

Where : $\beta = \frac{\text{useful or partial load}}{\text{safe working load}}$

$$\gamma = \frac{\text{dead load}}{\text{safe working load}}$$

$$t = \frac{\text{operating time under useful or partial load and dead load}}{\text{total operating time}}$$

$$t_\Delta = \frac{\text{operating time under dead load only}}{\text{total operating time}}$$

Four load spectra are distinguished which are determined by the definitions given and by the ranges covered by the cubic mean values k as listed in table 2

Load spectrum		Definitions	Cubic mean value
FEM	BS		
1 (light)	L1	Mechanisms or parts thereof, Usually subject to very small Loads and in exceptional cases Only to maximum loads	<p>$k \leq 0.50$</p>
2 (medium)	L2	Mechanisms or parts thereof, Usually subject to small loads But rather often to maximum loads	<p>$0.50 < k \leq 0.63$</p>
3 (heavy)	L3	Mechanisms or parts thereof, Usually subject to medium Loads but frequently to Maximum loads	<p>$0.63 < k \leq 0.80$</p>
4 (very heavy)	L4	Mechanisms or parts thereof, Usually subject to maximum or almost maximum loads	<p>$0.80 < k \leq 1.00$</p>

The formular given above for the cubic mean value k excludes the weight of the load carrying means. This is acceptable if the ratio

$$\frac{\text{Weight of the load carrying means}}{\text{safe working load}} \leq 0.05$$

By applying the classes of operating times and the load spectra, the mechanisms are classified in to 8 groups :

Classification of mechanisms into groups

Load spectrum			Class of operation time								
			V 0.06	V 0.12	V 0.25	V 0.5	V 1	V 2	V 3	V 4	V 5
			T 0	T 1	T 2	T 3	T 4	T 5	T 6	T 7	T 8
			Average operating time per day in hours								
FEM	BS	Cubic mean value	≤ 0.12	≤ 0.25	≤ 0.5	≤ 1	≤ 2	≤ 4	≤ 8	≤ 16	> 16
1 (Light)	L1	$k \leq 0.50$			1 D _m	1 C _m	1 B _m	1 A _m	2 _m	3 _m	4 _m
					M1	M2	M3	M4	M5	M6	M7
2 (medium)	L2	$0.50 < k \leq 0.63$		1 D _m	1 C _m	1 B _m	1 A _m	2 _m	3 _m	4 _m	5 _m
				M1	M2	M3	M4	M5	M6	M7	M8
3 (heavy)	L3	$0.63 < k \leq 0.80$	1 D _m	1 C _m	1 B _m	1 A _m	2 _m	3 _m	4 _m	5 _m	
			M1	M2	M3	M4	M5	M6	M7	M8	
4 (very heavy)	L4	$0.80 < k \leq 1.00$	1 C _m	1 B _m	1 A _m	2 _m	3 _m	4 _m	5 _m		
			M2	M3	M4	M5	M6	M7	M8		

The result of the classification of mechanism into groups according to table 3 is that the same life, expressed in years, may be expected for these machines under all load spectra and average operating times per day. This applies on condition that the life of the individual component depends on the third power of the load.

The average daily operating time within the classes of operating times are doubled as follows:

1. Within a group by passing into a lower load spectrum (progression 1.25), because $1.25^3 = 2$.
2. Within a load spectrum by passing into a higher group and derating the SWL by the factor of 1.25, because $1.25^3 = 2$



7084
CRANE 1: MASTER

 **Street**





ZX HOIST : optional features / equipment.

- SC Smartdrive on traverse motions minimises load swing.
- Fast and extra fast hoist speeds for shorter handling times.
- 10 : 1 hoist creep speed for the most precise handling.
- One step traverse limit switches (slowdown or stop).
- Two step traverse limit switches (slowdown and stop).
- Second hoist brake mounted on hoist motor.
- Standby cooling fan in hoist and trolley motor.
- Load Indication Display.
- Load summation between two hoists.
- Visual or audible overload warning.
- Frequency inverter on hoist motor.
- Non-standard traverse speeds.
- Push-button pendant on hoist.
- Special voltages.
- Overspeed switch applies the hoist brake if the gearbox shaft is running more than 10% over normal speed.



SC Smartdrive Technology.

The New ZX hoist incorporates **SC SMARTDRIVE**, the latest, most advanced traverse speed control technology to give the superior performance you might expect from a world leader.

ZX beats the competition by employing a full frequency inverter and current vector control for minimum load swing and easy, more accurate load positioning for greater safety and productivity.



- SC SMARTDRIVE is based on the latest inverter technology utilising dual CPU control and S-Ramp profiles on travel drives, to ensure smooth acceleration and controlled stopping with minimised load swing and increased efficiency and safety.
- Sensorless Current Vector method of motor control out-performs the Voltage Frequency method used by some competitors with respect to starting torque, speed holding and consistent slow speed performance.
- The SC SMARTDRIVE inverter includes an LED status display to access a series of diagnostic and condition monitoring data, including Safe Working Period calculation.
- Mechanically more robust inverter unit with increased vibration resistance (up to 0.65g at 20 to 50 Hz).
- Plug-in Control Terminal Board with memory is another significant advantage and another uncommon feature on standard cranes and hoists. It provides for a simple change in the unlikely event the inverter fails with no need for any re-programming tools.
- Inverter is CE UL cUL and TUV approved and is suitable for environments with Relative Humidity of 95% (non-condensing). It has a broad input range of 380 - 480 Volts -15% +10%.
- SC SMARTDRIVE Standard programming is for 2 speeds with standard smooth acceleration and deceleration ramps but the inverters are fully programmable for different speeds and accelerations, multiple speeds, ramp and hold or infinitely variable between full speed and 10% of full speed.





www.streetcrane.co.uk

Distributed By :

บริษัท ไทแทน เซอร์วิส จำกัด

1/19 หมู่ 1 ต.พิมพา อ.บางปะกง จังหวัด ฉะเชิงเทรา 24180 ประเทศไทย

TAX ID 0245554000604 TEL.038-989-373 ถึง 76 FAX.038-989-377

LINE.@titanservice Email. titanservice@live.com

Website. www.titanservice.co.th Facebook.com/Titanservicecompany